



pk trucks holland

Showroom: Graanweg 2 (M200)
4782 PP Moerdijk
The Netherlands

Tel. : +31 168 382 032
Fax : +31 168 382 023
E-mail: pktrucks@pktrucks.com

Renault Kerax 330.19 4x2 MD chassis cabin - NEW

ENGINE DXi11

Maximum engine Power : 243KW (330 hp) from 1400 to 1950 rpm.
Engine Torque : 1650 Nm from 1000 to 1400 rpm.
6-cylinder in-line diesel engine, turbocharged with INTERCOOLER and wastegate (for 410 / 450 hp). High-pressure electronic fuel-injection (2000 bars) by unit injector pumps. 24-valve, overhead camshaft, monobloc cylinder head, timing gear mounted in the rear. Bore 123 mm - stroke 152 mm - capacity 10.8 litres. Engine oil capacity: 36 litres. Steel oil sump. High-capacity throw-away oil filter. Cooling system capacity: 33.5 litres (51 litres with hydraulic retarder).
Piloted starting. Electronically piloted fan. Direction of rotation (seen from G/B end): anti-clockwise.
EEC EURO 3 exhaust emissions level.
PTO speed limiter.
Coolant anti-freeze protection: - 25°C.

ENGINE EQUIPMENT

Exhaust brake
Aluminium housing clutch flywheel
Electronic idling control.

CLUTCH

Clutch 430 GD 900 (430MFZ on Optidriver)
Single-plate. Air-assisted hydraulic actuation.
Automatic clearance adjustment.

GEARBOX

ZF 16S 1830 TO
16 forward synchronised gears and 2 reverse gears (13.8 - 0.84). Aluminium casing. Air splitter unit with pre-selection valve on the lever. Super H gear selection grille. Gear change assist by SERVOSHIFT. Cable controls. Economical driving assistance (DMS - Driving Monitoring System).

RETARDER

Exhaust brake retarder (135 Kw at 2100 rpm on DXi11, 193kW à 2300 rpm on DXi13) with constant solenoid valve control (between 2 and 7.5 bars).

POWER TAKE-OFF

Gearbox mounted PTO: S81 C.
Splined output for flanged pump. Rotation: opposite to engine..
Torque: 1000 Nm on mechanical g,box, 800 Nm on Optidriver.
Ratios:
0.9 / 1.09 (16S TO) ; 0.70 / 0.90 (Optidriver+ AT) ;
0.88 / 1.1 (Optidriver+ ATO)
REAR DRIVE AXLE
P 1361 rear axle with hub reduction (3.46).
Rear axle ratio 20 x 27 (ratio 1.35).

STEERING

Hydraulic power assistance.
Integral hydraulic power assistance (1 independant circuit and 1 pump).

AXLE

Load capacity: Front axle: 7.5 t.

WHEELS AND TYRES

B. 1200 R20 R187 / R187
Steel roadwheels.
Front wheel embellishers.
Spare wheel and tyre supplied loose.

BRAKING SYSTEM

Main brake :
Electropneumatic braking system with two independent circuits,
Drum brakes.
Braking capacity <= 70tonnes
Electronic APM (Air Product Management): cartridge air dryer, optimised by preventive maintenance. compressor disabled during engine starts.

Compressor: Twin-cylinder 636 cm³ piloted by APM. Decutching. Max. output: 660 litres/min at 2000 rpm (compressor). Ratio: 1.31

DRUM:

Diameter: 410 mm. Front width: 175 mm. Rear width: 225mm. Brake lever 170 mm. Total linings area: 10 299 mm². Vertical brake cylinders.

Parking brake :

Air operated springs brake actuators on drive axle.
Emergency brake :
Provided by the independance of the two separate circuits.

Brake adjustment :
Automatic adjustment.

CAB

EXTERIOR:

All steel Cab, iron-zinc coated and cataphoretic paint treatment.
Global cab 2-door.
Front panel with honeycomb radiator grille.
Anti-spray deflectors.
Cab 4-point mechanical suspension.
Hydraulic cab tilt mechanism.
2 manually adjustable rearview mirrors.
Tinted, laminated windscreen and tinted windows.
Air intake ducting on left side of roof.
Access to driving position by 3 lit steps. Flexible 1st step made from composite material.
Unskidable windscreen access step.
Rear window.
Sun-shade.

www.pktrucks.com



pk trucks holland

Showroom: Graanweg 2 (M200)
4782 PP Moerdijk
The Netherlands

Tel. : +31 168 382 032
Fax : +31 168 382 023
E-mail: pktrucks@pktrucks.com

INTERIOR :

Normal roof equipped with storage ledge.
Storage box 50 L
Hand-operated roof air vent.
Cab soundproofing.
Grab handles.
Adjustable driver's seat with seat belt, legroom adjustment for resting period.
Fixed passenger's seat with seat belt.
Head Restraint
Storage compartments in both doors.
Removable storage cases (21l) back on passenger seat.
Soft Door Trim
Boot socket on gear lever console.
Integrated air conditioner with manual regulation
Radio CD : Tuner FM / AM, CD player. 2 HP
130mm Woofer, 2 HP19mm Tweeter .
Remote controls at steering wheel.
Fire extinguisher capacity 2 kg.
Onboard Driving & Servicing handbook in Export English.

INSTRUMENT PANEL :

Electronic dashboard with :
- numeric display for speed & rpm.
- external temperature & time display.
- analogic oil level, water temperature & air pressure display.
- warning light.
- numeric display for secondary driving information.
- anti-reflection screen
Information display lighting intensity and sound level adjustment. Lights not switched on alert.
Drinking cup location or removable ashtray.

LIGHT CABINE ADJUSTMENT

Cigar-lighter
Instrument panel bleed control.
DIAG socket.
Access hatch to fuses and bodybuilder module box (BBM).

STEERING-MOUNTED EQUIPMENT:

Steering lock.
Retarder or engine brake control (if equipped).
Two speed windscreen wipers with incorporated washers and intermittent wipe.
Headlight control.
Adjustable steering column.

ELECTRICAL EQUIPMENT

Battery capacity: 170 Ah
Alternator 110 A.
24V voltage supplied by two batteries. Master switch and fuse box in battery tray.
Lighting to EEC standards.
Electrical headlights beam adjuster.
Round tail lights.

CHASSIS

Bad road condition usage - construction
XPERT Version heavy duty conditions adapted, electronic box.
Reminder :
- Dashboard "eco" without non vital failure
- Inter axle differential blocking inter wheel in rear speed position
- Protection for APM, mult "T", clutch, inter wheel, inter axle locking.
- Inter axle reinforced transmission
- oil level indicator on front side
Chassis width: Front: 1080 Rear: 850 Side members module: 300 x 90 x 8. Side member lining: 5 mm. Necking of chassis under cab.
Normal rear overhang, Pre drilled for Body Builder.
3-piece steel shield integrating retractable windscreen access step, front grille, radiator protection shoe and towing yoke.
Windscreen additional Foot-Board
Detachable front towing yoke (25 tonnes) with unlocking by 1/4 turn lock.
Chassis rear cross-member.
Tool box on chassis 55L
Without rear run-under guard..
Tail lamps mounted on dedicated bracket.

SUSPENSION

Front :
Maintenance-free front parabolic 2-leaf springs (8 tonnes).
Front anti-roll bar.
Rear :
Parabolic rear suspension.
Rear suspension capacity 15T with 4 leaf
Rear anti-roll bar.
Telescopic shock absorbers.

FUEL TANK

Main steel tank : 415 litres capacity. (348 kg of diesel) D- shaped 560 mm diam.
Locking fuel filler cap.
Without fuel heater.

STANDARD EQUIPMENT

Side exhaust.
Dusty surroundings air filtration.
Onboard kit.
. Hydraulic jack - Tool kit.
Advance warning triangle.
Reversing buzzer.
Headlamp protective grille.

BODYWORK

Bodybuilder electronic box interface.
Power supply terminal plate 24V / 200A in battery tray. Round 7-pin socket provision under battery tray:- After master switch power supply 24V / 15A + earth (cab shared).- After ignition power supply

www.pktrucks.com



pk trucks holland

Showroom: Graanweg 2 (M200)
4782 PP Moerdijk
The Netherlands

Tel. : +31 168 382 032
Fax : +31 168 382 023
E-mail: pktrucks@pktrucks.com

Engine speed at 90 km/h : 1732 rpm

Weights and dimensions

GVW kg.....	19000
Max. Body Length (W) mm	8542
Min. Body Length (W) mm	7303
Total Payload kg	11730
Chassis Cab Weight kg.....	7270
Front Load Distribution kg.....	4721
Rear Load Distribution kg.....	2549
Front Axle Max. Limit kg.....	7500
Rear Axle Max. Limit kg	13000
Max. Rear Overhang (X) mm.....	3477
Min. Rear Overhang (X) mm.....	2238
Max. Payload Centre of Gravity (Y) mm.....	1414
Min. Payload Centre of Gravity (Y) mm.....	794
Max. Vehicle Length (Z) mm.....	10760
Min. Vehicle Length (Z) mm.....	9521
Cab Start (B) mm.....	730
Wheelbase (F) mm.....	5795
Chassis Cab Rear Overhang (N) mm	3095
Chassis Cab Overall Length mm.....	10378
Chassis Height unladen (H2) mm	1187
Chassis Height laden (H2) mm	1093
Cab/Ground Height unladen (O) mm	3203
Front Overhang (H) mm.....	1488
Cab Width across WIngs mm.....	2500
Front Track (V1) mm.....	2017
Rear Track mm	1836
Width across Rear Wheels mm.....	2494
Front Ground Clearance mm	384
Rear Ground Clearance mm.....	340
Frame Width at Front mm.....	108
Frame Width at Rear mm.....	850
Overall Turning Radius mm	11050

This table includes the weights of selected RENAULT TRUCKS options. The dimensions remain those of the base vehicle.

www.pktrucks.com



pk trucks holland

Showroom: Graanweg 2 (M200)
4782 PP Moerdijk
The Netherlands

Tel. : +31 168 382 032
Fax : +31 168 382 023
E-mail: pktrucks@pktrucks.com

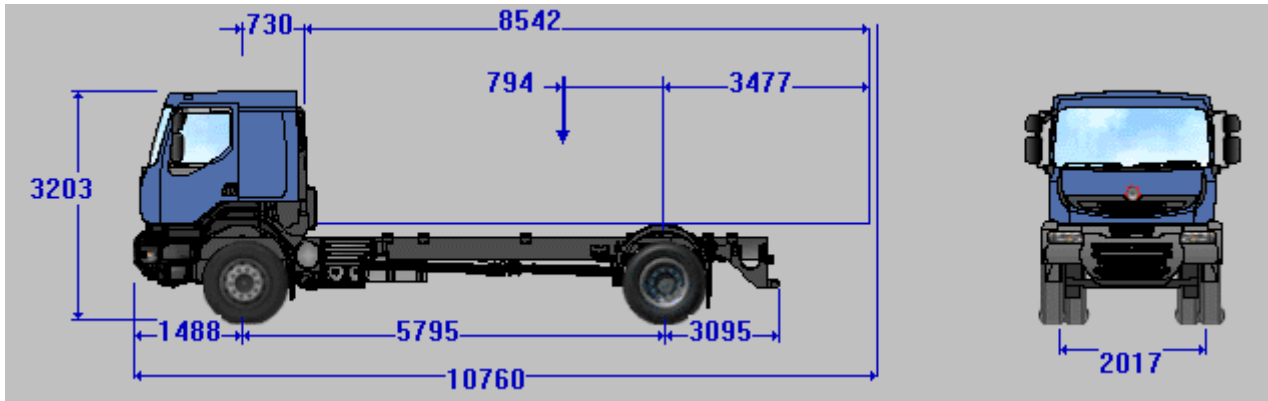

www.pktrucks.com